

MR6K-38

6000 lb Capacity Portable Mid-Rise Scissor Lift

Operation Manual



**6,000 LB.
PORTABLE
MID-RISE
FRAME LIFT**

A comfortable 38" working height, twin cylinders and double safety locks make this portable lift an exceptional value. The MR6K-38 is built for years of efficient, trouble-free service.

MR6K-38
Portable Mid-Rise
Frame lift



SPECIFICATIONS

	MR6K-38
Lifting capacity	6,000 lbs.
Overall width	76 1/2"
Overall length	77"
Track length	57 3/4"
Maximum lifting height	38"
Collapsed height	4"
Motor	1 hp 110 vac
Weight	1133 lbs.

Features:

- ◆ 6,000 lb. lifting capacity
- ◆ Automatic double safety lock system with air release
- ◆ 38" working height
- ◆ 4" drive-over height for approach of low vehicles
- ◆ Wheel kit, tow bar and rubber riser blocks standard
- ◆ Portable trolley for power unit and safety lock air release control

TUXEDO DISTRIBUTORS LIMITED WARRANTY

Structural Warranty:

The following parts and structural components carry a five year warranty:

Columns	Top Rail Beam	Uprights	Arms Swivel Pins
Legs	Carriages	Tracks Overhead Beam	Cross Rails

Limited One-Year Warranty:

Tuxedo Distributors, LLC ("Tuxedo") offers a limited one-year warranty to the original purchaser of Tuxedo lifts and Wheel Service in the United States and Canada. Tuxedo will replace, without charge, any part found defective in materials or workmanship under normal use, for a period of one year after purchase. The purchaser is responsible for all shipping charges. This warranty does not apply to equipment that has been improperly installed or altered or that has not been operated or maintained according to specifications.

Other Limitations:

This warranty does not cover:

1. Parts needed for normal maintenance
2. Wear parts, including but not limited to cables, slider blocks, chains, rubber pads and pulleys
3. Replacement of lift and tire changer cylinders after the first 30 days. A seal kit and installation instructions will be sent for repairs thereafter.
4. On-site labor

Upon receipt, the customer must visually inspect the equipment for any potential freight damage before signing clear on the shipping receipt. Freight damage is not considered a warranty issue and therefore must be noted for any potential recovery with the shipping company.

The customer is required to notify Tuxedo of any missing parts within 72 hours. Timely notification must be received to be covered under warranty.

Tuxedo will replace any defective part under warranty at no charge as soon as such parts become available from the manufacturer. No guarantee is given as to the immediate availability of replacement parts.

Tuxedo reserves the right to make improvements and/or design changes to its lifts without any obligation to previously sold, assembled or fabricated equipment.

There is no other express warranty on the Tuxedo lifts and this warranty is exclusive of and in lieu of all other warranties, expressed or implied, including all warranties of merchantability and fitness for a particular purpose.

To the fullest extent allowed by law, Tuxedo shall not be liable for loss of use, cost of cover, lost profits, inconvenience, lost time, commercial loss or other incidental or consequential damages.

This Limited Warranty is granted to the original purchaser only and is not transferable or assignable.

Some states do not allow exclusion or limitation of consequential damages or how long an implied warranty lasts, so the above limitations and exclusions may not apply. This warranty gives you specific legal rights and you may have other rights, which may vary from state to state.

CONTENT

1. Safety

Note, Caution and Warning
Important Information
Safety Instructions

2. Technical Manual

Product Description
Technical Data
Hydraulic Scheme

3. Before Using

Site Selection
Surface Condition
Installation Instruction
Preparation for Starting up

4. Operation Manual

Caution and Warning Label
Operation Instructions
Maintenance Instructions

5. Parts List

Safety Information

1.1 Note, Caution and Warning

This document uses the following conventions—Note, Caution and Warning – to alert you to special instructions, tips, or hazards for a given procedure. Please familiarize yourself with the conventions described below.

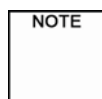

Indicates important information that requires special attention, such as a procedure for a specific vehicle, or tips on operating the equipment.



Indicates the potential for damage to equipment, accessories, or the vehicle unless you follow the instructions or procedure exactly.



Indicates the potential for property damage, personal injury, or death due to hazards associated with the equipment, vehicle, or environment. Do not perform any procedure until you have read and understood the warning instructions.

Important Information

1. Read this manual thoroughly before installing, operating, or maintaining this lift.
2. This lift is designed for indoor use only, and should not be installed in a pit or depression.
3. The lifts have specific electrical requirements as described in the Installation Instructions section of this manual.
4. This lift has a minimum ceiling height requirement as described in the Installation Instructions section of this manual.
5. Failure by the owner to provide the **recommended shelter, mounting surface, electrical supply, and ceiling height** could result in unsatisfactory lift performance, property damage, or personal injury.
6. The operation of the lift is permitted by authorized person only.

Safety Instructions

1. **Do not** raise a vehicle on the lift until the initialization is completed as described in this manual.
2. Technicians should be trained to use and care for the lift by familiarizing themselves with the publications listed above. The lift should **never be operated by an untrained person**.
3. Always position the pads properly out of the way before pulling the vehicle into, or out of the bay. Failure to do so could damage the vehicle and/or the lift.
4. **Do not overload the lift**. The capacity of the lift is shown on cover of this document and on the lift's serial number tag
5. Positioning the vehicle is very important. Only trained technicians should position the vehicle on the lift. **Never allow anyone to stand in the path of the vehicle as it is being positioned and never raise vehicle with passengers inside**.
6. Position the pads to the vehicle manufacturer's recommended pickup points. Raise the lift until contact is made with the vehicle. Make sure that the pads and the ramps have properly engaged the vehicle before raising the lift to a working height.
7. Keep everyone clear of the lift when the lift is moving, the locking mechanism is disengaged, or the vehicle is in danger of falling.
8. Unauthorized personnel should never be in the shop area when the lift is in use.
9. Inspect the lift daily. **The lift should never be operated if it has damaged components, or is malfunctioning**. Only qualified technicians should service the lift. **Replace damaged components with manufacturer's parts, or equivalent**.
10. **Keep the area around the lift clear of obstacles**.
11. **Never override the self-returning lift controls**.
12. Avoid excessive rocking of the vehicle when it is on the lift.
13. To reduce the risk of personal injury, keep hair, loose clothing, fingers, and all body parts away from moving parts.
14. To reduce the risk of electric shock, **do not** use the lift when wet, do not expose the lift to rain.
15. To reduce the risk of fire, **do not** operate equipment in the vicinity of open containers of flammable liquids (gasoline).
16. Use the lift only as described in this manual, **use only manufacturer's recommended attachments**.

17. **Unusual vehicles, such as limousines, RV's, and long wheelbase vehicles, may not be suitable for lifting on this equipment.** If necessary, consult with the manufacturer or the manufacturer's representative.
18. The maintenance procedures described in this manual can be done by the lift's owner/employer. Any other procedure should only be performed by trained lift service personnel. **These restricted procedures include, but are not limited to, the following: cylinder replacement, platform and safety latch replacement, motor replacement, control board replacement.**
19. Anyone who will be in the vicinity of the lift when it is in use should familiarize themselves with following Caution, Warning, and Safety related decals supplied with this lift, and replace them if they are illegible or missing.

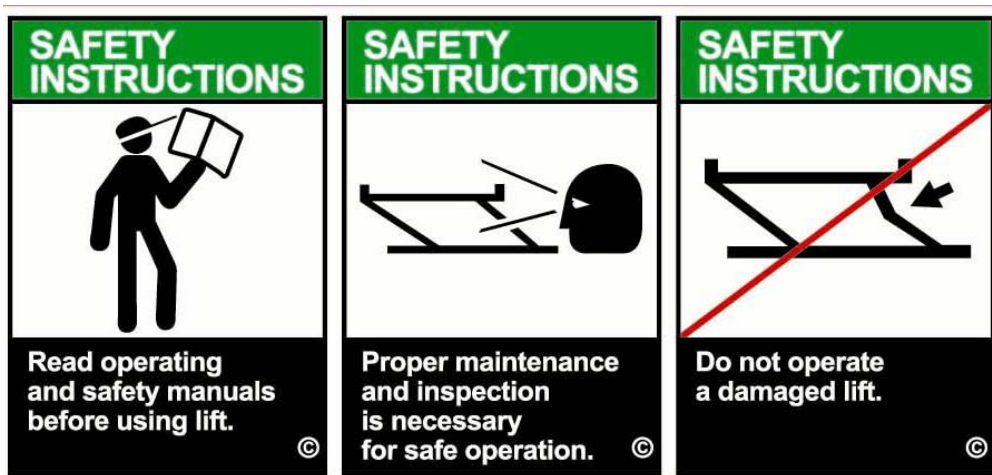

Disclaimers

The information contained in this manual was considered accurate at the time of printing and is subject to change without notification. Any corrections should be directed to LONGUS

2. Technical Manual

2.1 Product Description

The hydraulic mobile scissor lift is a manually mobile, frame contact lift incorporating the latest safety technologies. Designed and manufactured for a lifting capacity of 6,000lbs / 2,700kg, is fully capable for lifting cars, light vans and safely holding them in an elevated position.

The hydraulic mobile scissor lift consists of a fixed structural scissor lift, the mobile unit (wheels and trolley), the hydraulic power control system and safety devices.

2.2 Technical Data

Capacity	6000lbs (2,700 kg)
Lifting Height, Max	39 3/16" (995 mm)
Height, Min	4 5/16" (110 mm)
Width Overall	76 3/4" (1,950 mm)
Platform Length, Max	77 3/8" (1,966 mm)
Platform Width	18 1/8" (460 mm)
Width between platforms.	33 1/4" (845 mm)
Power Unit	110V, 60Hz, 20A, 1.8KW
Ambient Air Temperature	+41°F ~ +104°F
Ambient Air Humidity	30% ~ 95%
Altitude	below 3280ft (1,000 m) above sea level
Storage Temperature	-13°F ~ +131°F

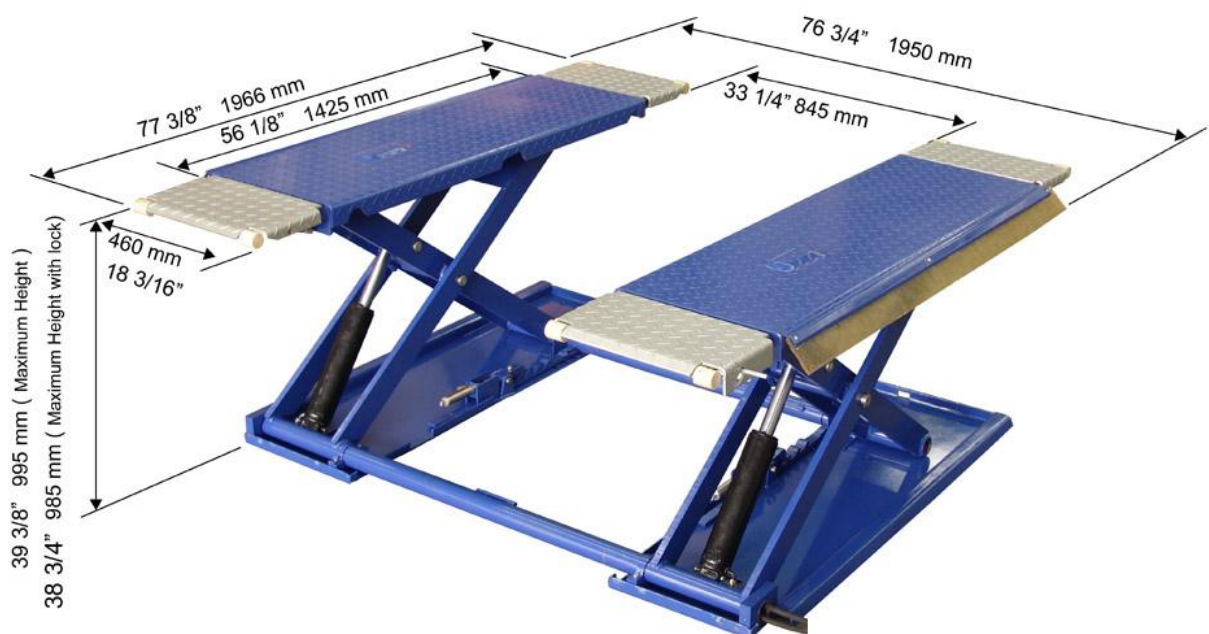

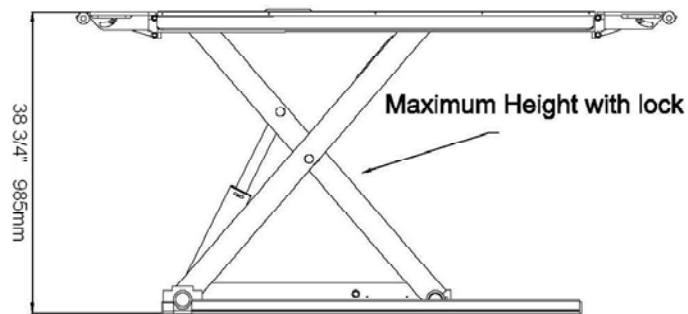
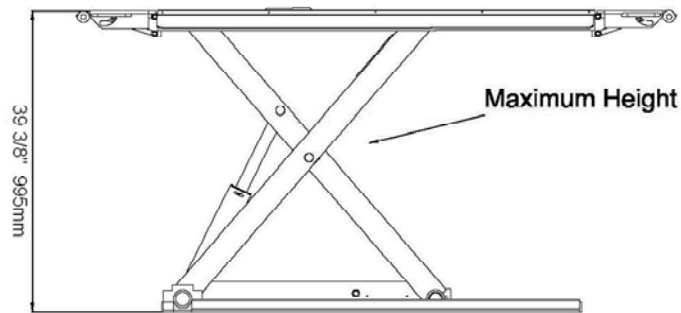
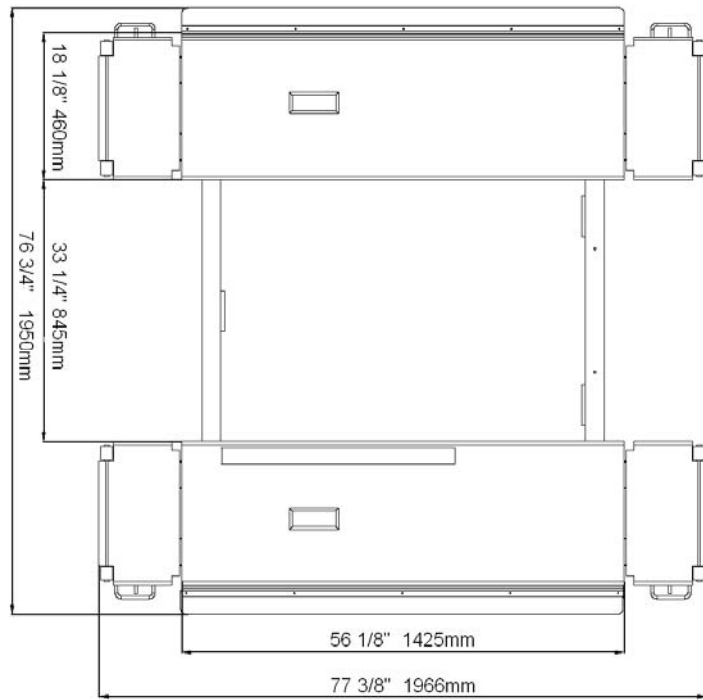
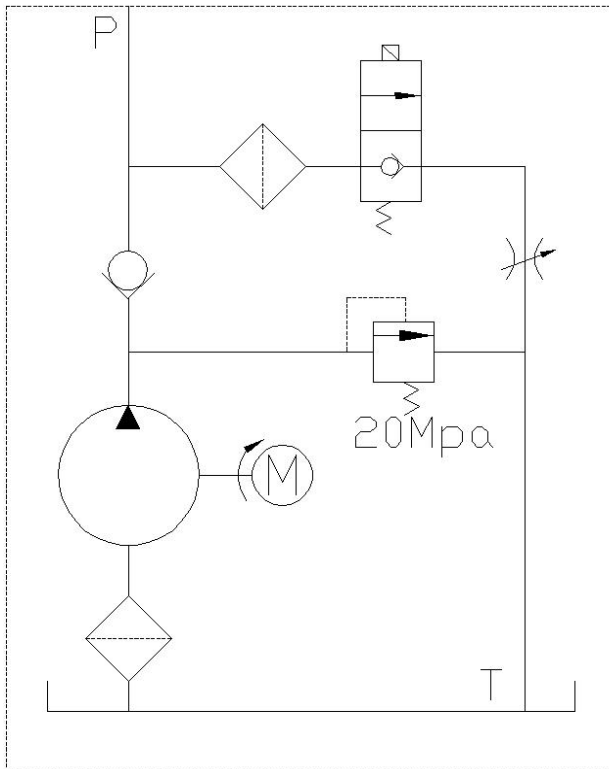

Figure 1 – General View

2.3 Hydraulic Scheme



3. Before Using

3.1. Site Selection

The hydraulic mobile scissor lift is designed for indoor use only. Application in a room with explosion hazard is not permitted. Setting in a wet place, a car wash center for instance, is forbidden.

3.2. Surface Condition

The hydraulic mobile scissor lift should be installed on level ground.



Failure to accomplish the foundation requirement may cause lift instability, which could result in personal injury. Installing on asphalt, soft clay floor or near the expansion gap is prohibited.

3.3. Installation Instruction

1. Install the ramps.

A. Install the Locking device

Insert the pin through the slot



B. Mount the spring nut

Clamp the spring nut on both end of the pin.



C. Mount the ramp

Insert the pin through the slot and clamp the Spring nut

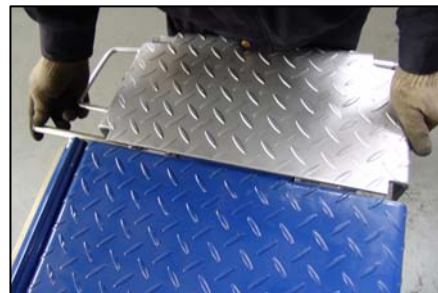

2. Connect with power unit

A. Mount the motor pump

Assemble the dolly then mount the motor pump on it.



B. Connect Oil hose

Connect both oil hoses with the connector on the valve block

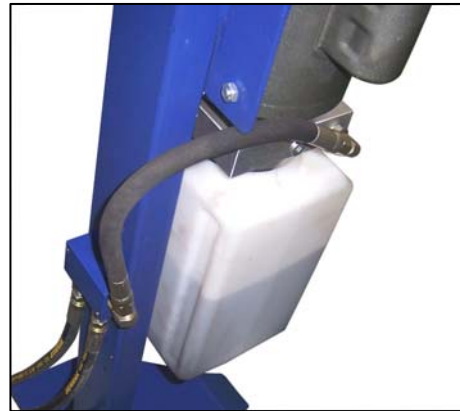

C. Connect the air tube

Connect the air tube (6mm) to the control valve block. P is for compressed air inlet and A is for linking to the air cylinder (safety lock).



D. Connect the power supply

Connect the power cable to the power supply .
110V/60Hz, single phase, 20A

3. **Lubricate the sliding pieces with heavy duty bearing grease.**

4. **Final Adjustment.**

A. If any problems are encountered, **do not** proceed with subsequent steps. Instead, resolve the problem before proceeding by referencing the troubleshooting portion of the Owner's Manual section of this manual.

B. Raise the lift to full height. Lower the lift onto the safety latches. Raise the platforms, pull out both latch pull rods, and lower the lift to the ground.

C. Raise the lift empty to the top of its travel and lower it to the floor three (3) times to remove the remaining air from the hydraulic system.

D. **The latches should click together as the lift is being raised.**

E. When the platforms are lowered onto the locks, **neither pull rod should be capable of being pulled out.**

F. **The first time a vehicle is placed on the lift, raise it no higher than 500 mm.** Lower the vehicle onto the safety latches. Raise the lift higher (about 200 mm) and open both latch pull rods then lower the vehicle to the floor.

G. Raise the vehicle to full height and lower the platforms onto the safety latches. Lower the vehicle to the floor.

H. After cycling the lift **ten times** with a vehicle on it, **recheck the tightness of the screws in the basement.**

3.4. Preparation for Starting up

3.5.1. The latch is **engaged** when installed in the column.

3.5.2. The hydraulic oil should be ISO-22.

3.5.3. Have a certified electrician establish a 110V/60Hz/20A power supply to motor and overheated switch. A protection against indirect contact (RCCB) needs to be provided by the user

3.5.4. Air Evacuation. There may remain little air in the hose or cylinder during installation. Operating the lift up and down in the working height several times without load.

4. Operation Manual

Be sure to read and familiarize yourself with the Safety Instructions at the beginning of this manual. Failure to follow Safety Instructions may result in property damage, personal injury or death.

4.1 Caution and Warning Label

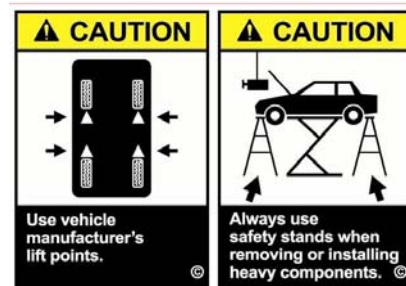

4.2 Operating Instructions



Be sure to read and familiarize yourself with the Safety Instructions at the beginning of this manual. Failure to follow Safety Instructions may result in proper damage, personal injury or death.



To avoid personal injury and/or property damage, permit only trained personnel to operate lift. After reviewing these instructions, get familiar with lift controls by running the lift through a few cycles before loading vehicle on the lift.



Always lift the vehicle using all four adapters. **NEVER** raise just one end, one corner, or one side of vehicle.



The heavy end of the vehicle **MUST** put on the side as shown in the figure.

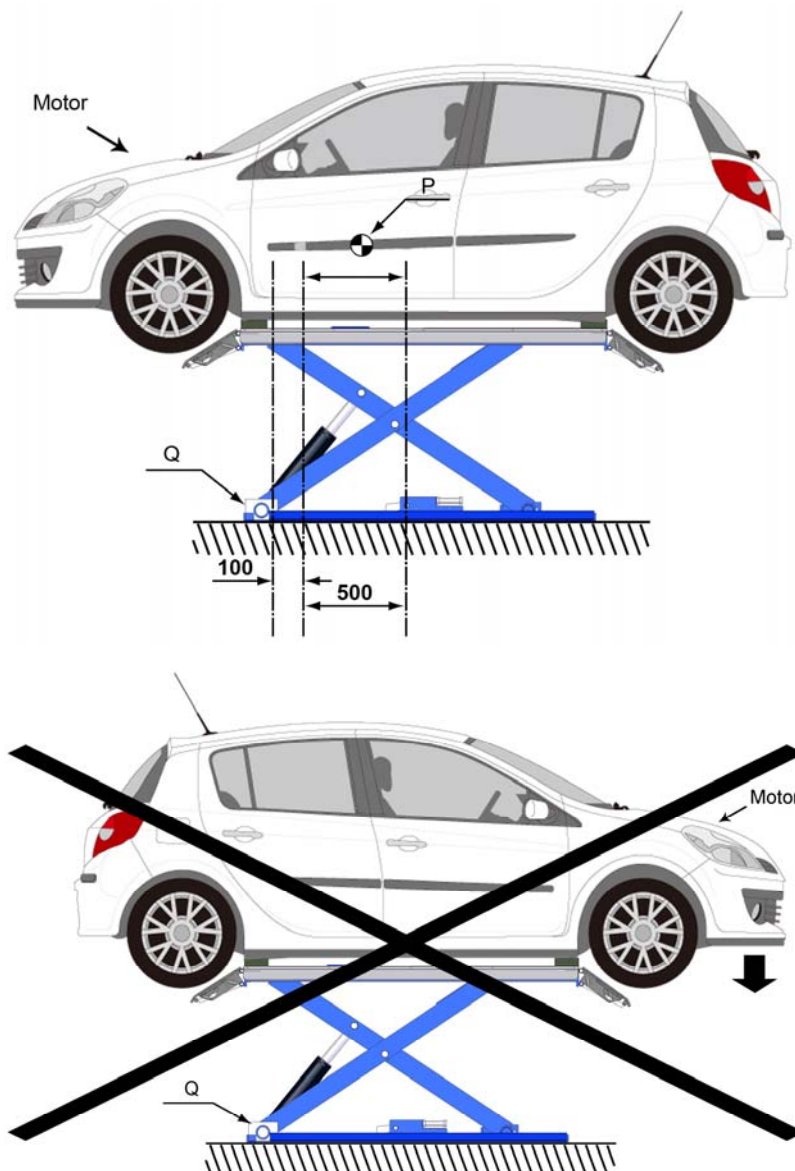

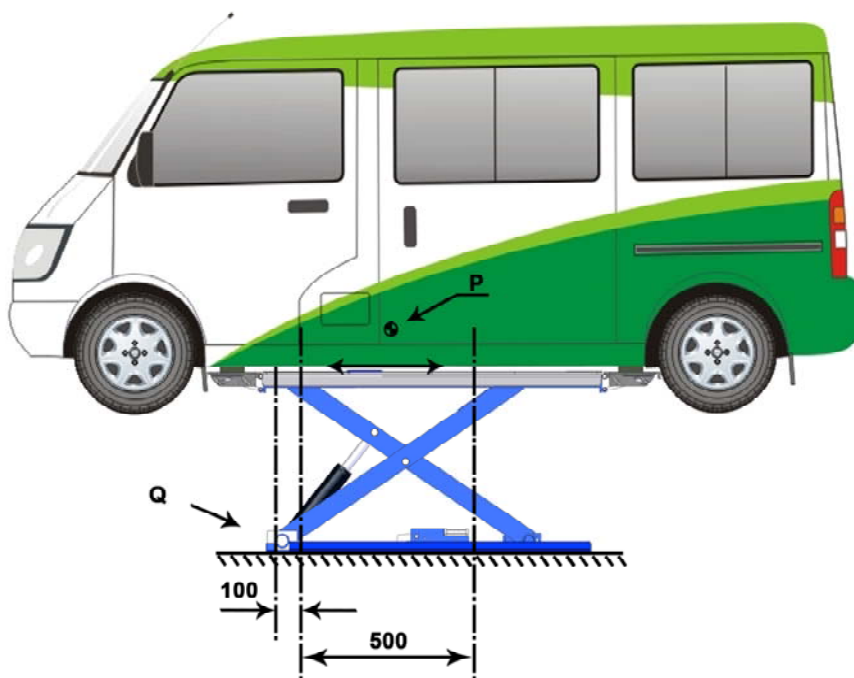
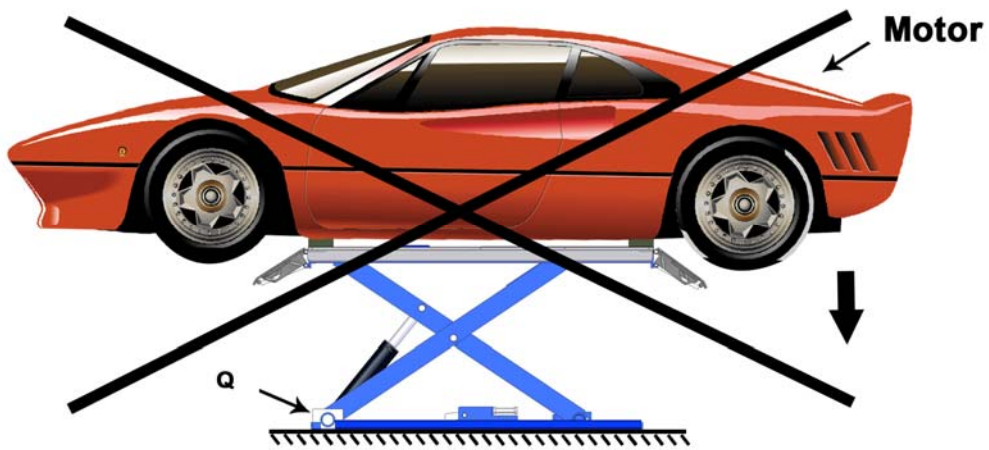
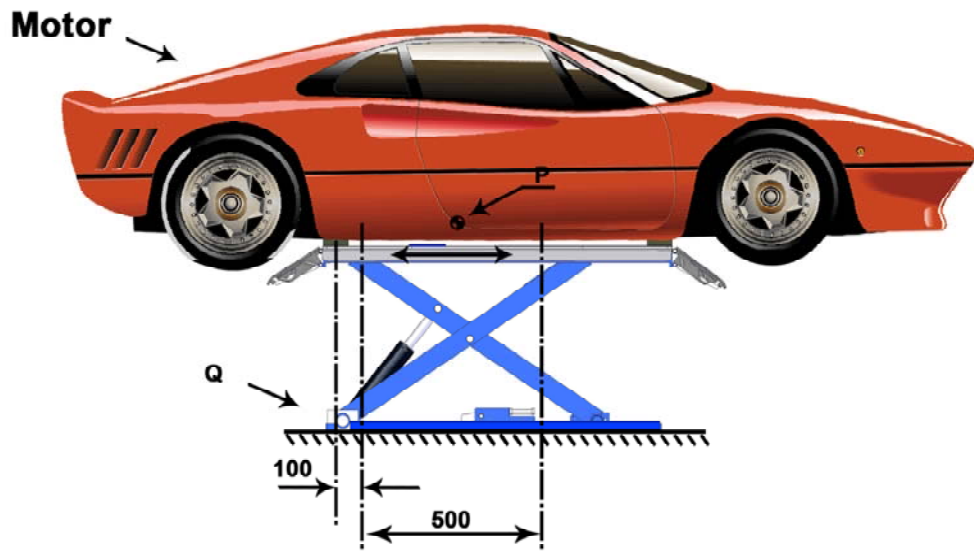

4.2.1 Lift Preparation:

Lift must be fully lowered and fields clear of all personnel before a vehicle is put on the lift.

4.2.2 Loading Lift:

Position the adapter at vehicle manufacturer's recommended lift points. Use intermediate, high step, or optional adapters for under body clearance when required.



Typical Lifting Points. Some vehicles may have the manufacturer's Service Garage Lift Point locations identified by triangle shape marks on it's underplatform. Also, there may be a label located on the right front door lock face showing specific vehicle lift points. If the specific vehicle lift points are not identified, refer to the vehicle operation manual or consult the vehicle agent. ALWAYS follow the operating instructions supplied with the lift.

4.2.3 To Raise Lift

- a. Push UP button on motor.
- b. Raise lift until it touches the frame of the vehicle.
- c. Check support adapters for secure contact at vehicle manufacturer's recommended lift points.
- d. Continue to raise to desired height only if vehicle is secure on lift
- e. Repeat complete spotting, loading and raising procedures if required.
- f. Push the release lever to lower the vehicle to the locking position.



DO NOT go under vehicle if locking latches are not engaged.



Before attempting to lift pickup trucks or other truck frame vehicles, be sure that:

- **Vehicle frame is strong enough to support it's weight and has not been weakened by modification or corrosion.**
- **Vehicle individual axle weight does not exceed one-half lift capacity.**
- **Adapters are in secure contact with frame at vehicle manufacturers recommended lift point.**
- **Vehicle is stable on lift**

4.2.4 To Lower Lift

- a. Check all danger points of the lift and be sure that there are no objects or people in the working area (danger area) around the lift or on the lift.
- b. In order to lower the lift to the required working height or to its lowest (or fully collapsed) position, First raise the lift approx. 2" to clear the locking latches. Then push the air-valve button and when keeping it be pressed, push the release lever on the motor pump.
- c. Observe the complete lowering process.
- d. When the lift is in its lowest position, remove the polymer supports.
- e. Drive the vehicle off the lift.



Remain clear of lift when lowering vehicle. Observe pinch point warning decals.



If lift is not operating properly, DO NOT use until adjustment or repairs are made by qualified lift service personnel.

4.2.5 Change the installation place

- a. Lower the lift in the lowest position.
- b. Drive the vehicle from the lift.
- c. Raise the lift to a height of approx. 500mm.
- d. Use the mobile set. Put in the steering roller and the fixed roller.
- e. Lower the lift into the lowest position. Simultaneously, the base-plates will lift themselves.
- f. Now the automotive lift is movable.
- g. Remove the steering rod once the lift is in its new location.
- h. Remove the mobile set.



MOBILE SET



MOVING THE LIFT

4.3 Maintenance Instructions

Contact your service provider for instruction before starting up if you are not completely familiar with automotive lift maintenance procedures. Only qualified personnel can perform maintenance on this equipment. Any failure in operation may cause personal injury or death.

- ✓ Always keep bolts tight. Check periodically.
- ✓ Always keep lift components clean.
- ✓ If oil leakage is observed, contact your service provider.
- ✓ Check cables and sheaves for wear everyday. Replace worn or broken parts with lift manufacturer's parts, or their equivalent.

Every Month

- ✓ Lubricate locking latch shafts. Push latch handle several times for oil to penetrate joints.
- ✓ Lubricate the four inside corners of the legs with heavy duty bearing grease.
- ✓ With lift lowered check the hydraulic fluid level. If necessary add oil as described in the Installation Instruction section of this manual

Check platform latch synching: Latches should click at the same time.

- ✓ Check tightness of all bolts.
- ✓ Check the nuts for tightness every week for the first month, and every month afterwards.

Every 3 Months

- ✓ Check and clean the oil filter

Every 6 Months

- ✓ Check fluid level of lift power unit and refill if required.
- ✓ If Lift stops short of full rise or chatters, contact your service provider.
- ✓ Replace all caution, warning or safety related decals on the lift If unable to read or missing. Reorder labels from service provider.

5. Parts List

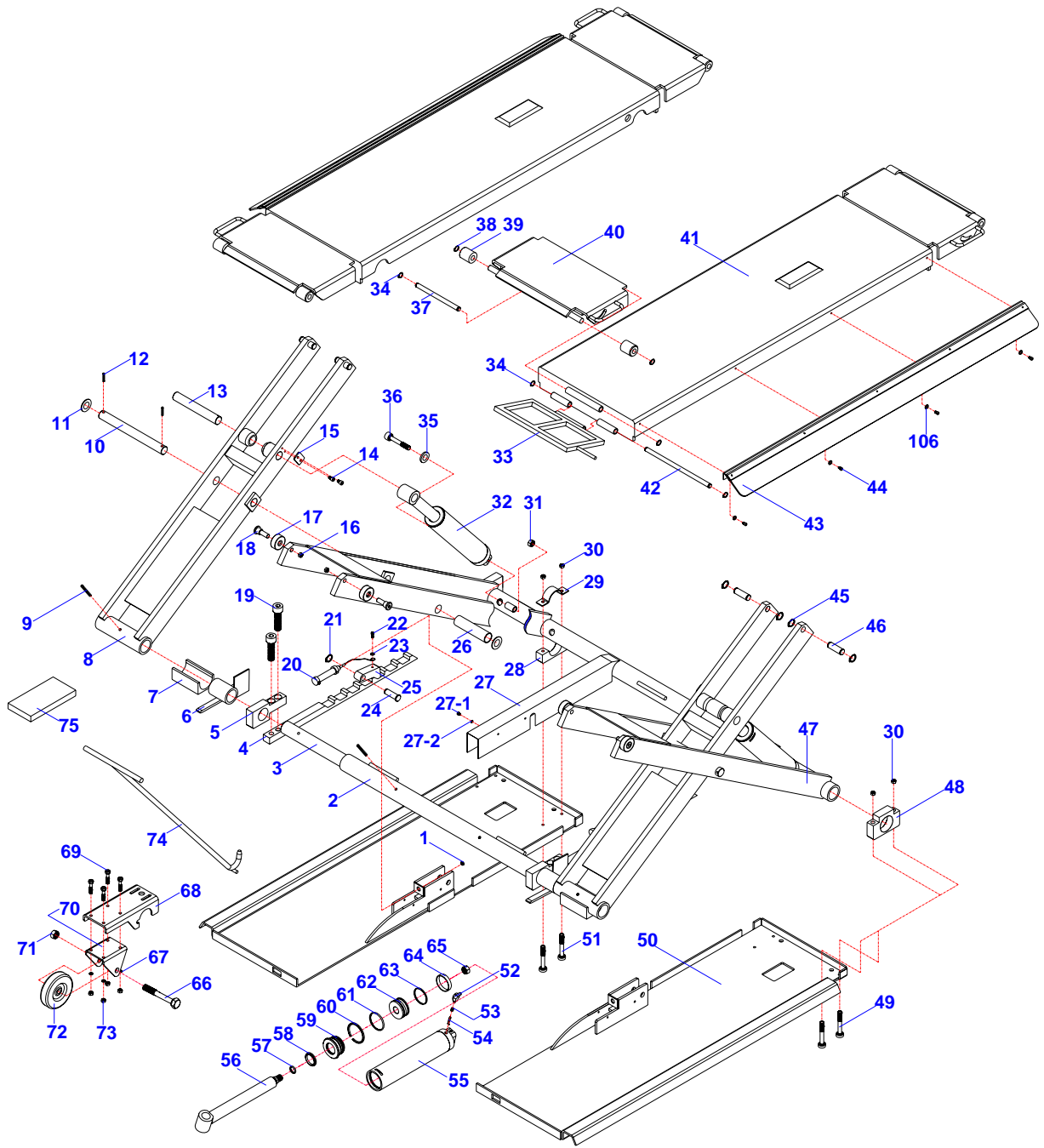

CODE	Part Number	DESCRIPTION	Quantity
1	1611081001	Flat nut	4
2	1611081002	Connection pipe jointing	1
3	1611081003	Spindle	1
4	1611081004	Safty rack	2
5	1611081005	Spindle spacer	2
6	1611081006	Safty limit assy	2
7	1611081007	Half moon block	2
8	1611081008	Inner scissor frame	2
9	1611081009	Elastic pin	4
10	1611081010	Spindle	2
11	1611081011	Washer	4
12	1611081012	Elastic pin	4
13	1611081013	Position plate	2
14	1611081014	Hex screw	4
15	1611081015	Position plate	2
16	1611081016	Hex nut	4
17	1611081017	Upper block	4
18	1611081018	Hex bolt	4
19	1611081019	Hex screw	4
20	1611081020	Air cylinder	2
21	1611081021	Elastic washer	2
22	1611081022	Hex bolt	2
23	1611081023	Flat washer	2
24	1611081024	Spindle	2
25	1611081025	Safty hook	2
26	1611081026	Spindle spacer	2
27	1611081027	Safty cover	2
27-1	1611081027-1	Cross bolt	4
27-2	1611081027-2	Flat washer	4
28	1611081028	Support bracket	2
29	1611081029	Fixed plate	2
30	1611081030	Hex nut	8
31	1611081031	Nylon nut	2
32	1611081032	Cylinder assy	2
33	1611081033	Ramp support assy	4
34	1611081034	Elastic washer	16
35	1611081035	Washer	2
36	1611081036	Hex screw	2
37	1611081037	Ramp connection spindle	4

CODE	Part Number	DESCRIPTION	Quantity
38	1611081038	Elastic washer	8
39	1611081039	Idler wheel	8
40	1611081040	Ramp assy	4
41	1611081041	Platform assy	2
42	1611081042	Connection spindle assy	4
43	1611081043	Protection plate	2
44	1611081044	Hex bolt	8
45	1611081045	Elastic washer	8
46	1611081046	Position pin	4
47	1611081047	Outer scissor frame	1
48	1611081048	Position spindle assy	2
49	1611081049	Cross bolt	4
50	1611081050	Underframe assy	2
51	1611081051	Cross bolt	4
52	1611081052	Union	2
53	1611081053	Throttling washer	2
54	1611081054	Spring	2
55	1611081055	Cylinder jointing	2
56	1611081056	Piston rod jointing	2
57	1611081057	O-ring	2
58	1611081058	Dust-ring	2
59	1611081059	Cylinder cover	2
60	1611081060	Washer	2
61	1611081061	O-ring	2
62	1611081062	Piston	2
63	1611081063	Seal ring	2
64	1611081064	Guide ring	2
65	1611081065	Hex nut	2
66	1611081066	Hex bolt	3
67	1611081067	Flat washer	12
68	1611081068	Dragging position plate	3
69	1611081069	Hex bolt	12
70	1611081070	Fixed plate for wheel	3
71	1611081071	Hex nut	3
72	1611081072	Idler wheel	3
73	1611081073	Nylon nut	12
74	1611081074	Dragging handle assy	1
75	1611081075	Rubber washer	4
106	1611081106	Flat washer	8

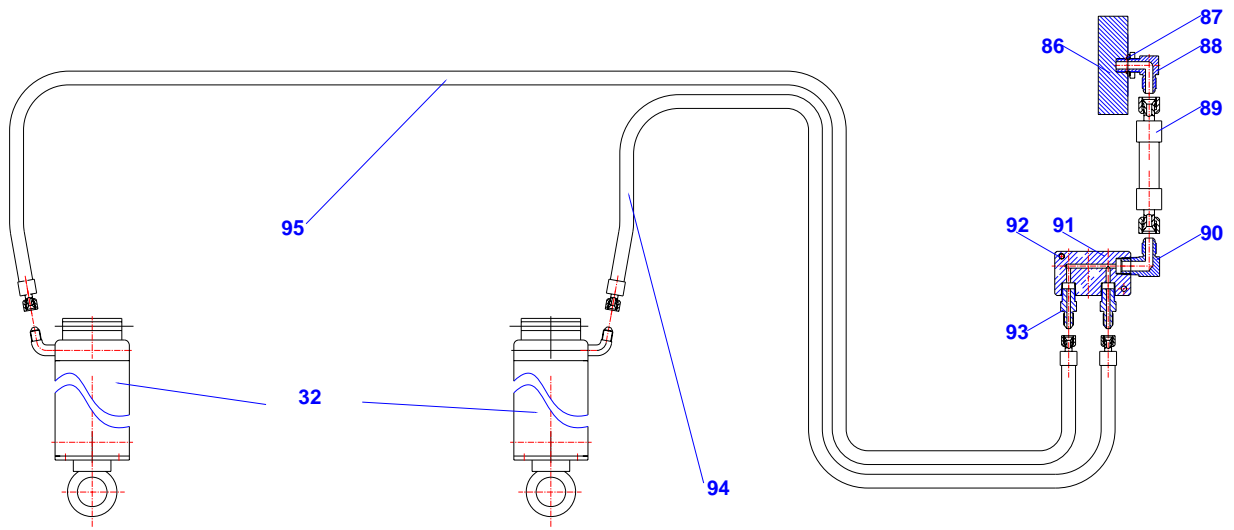

CODE	Part Number	DESCRIPTION	Quantity
32	1611081032	Cylinder assy	2
86	1611081086	Valve block	1
87	1611081087	O-ring	1
88	1611081088	Oil union	1
89	1611081089	Oil hose assy	1
90	1611081090	Direct union	1
91	1611081091	T union	1
92	1611081092	Hex bolt	2
93	1611081093	Union	2
94	1611081094	Short oil hose assy	1
95	1611081095	Long oil hose assy	1

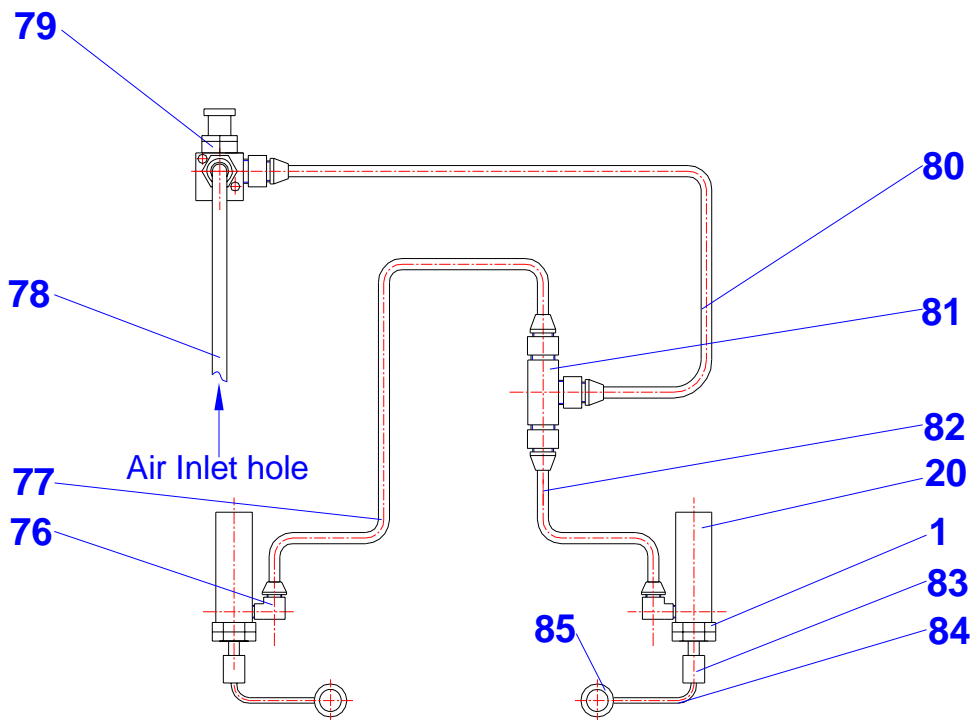

CODE	Part Number	DESCRIPTION	Quantity
1	1611081001	Flat nut	4
20	1611081020	Air cylinder	2
76	1611081076	Direct union	2
77	1611081077	Air hose(1)	1
78	1611081078	Air hose(2)	1
79	1611081079	Air valve	1
80	1611081080	Air hose(3)	1
81	1611081081	Air union	1
82	1611081082	Air hose(4)	1
83	1611081083	Adjustable nut	2
84	1611081084	Steel cable	2
85	1611081085	Loop	2

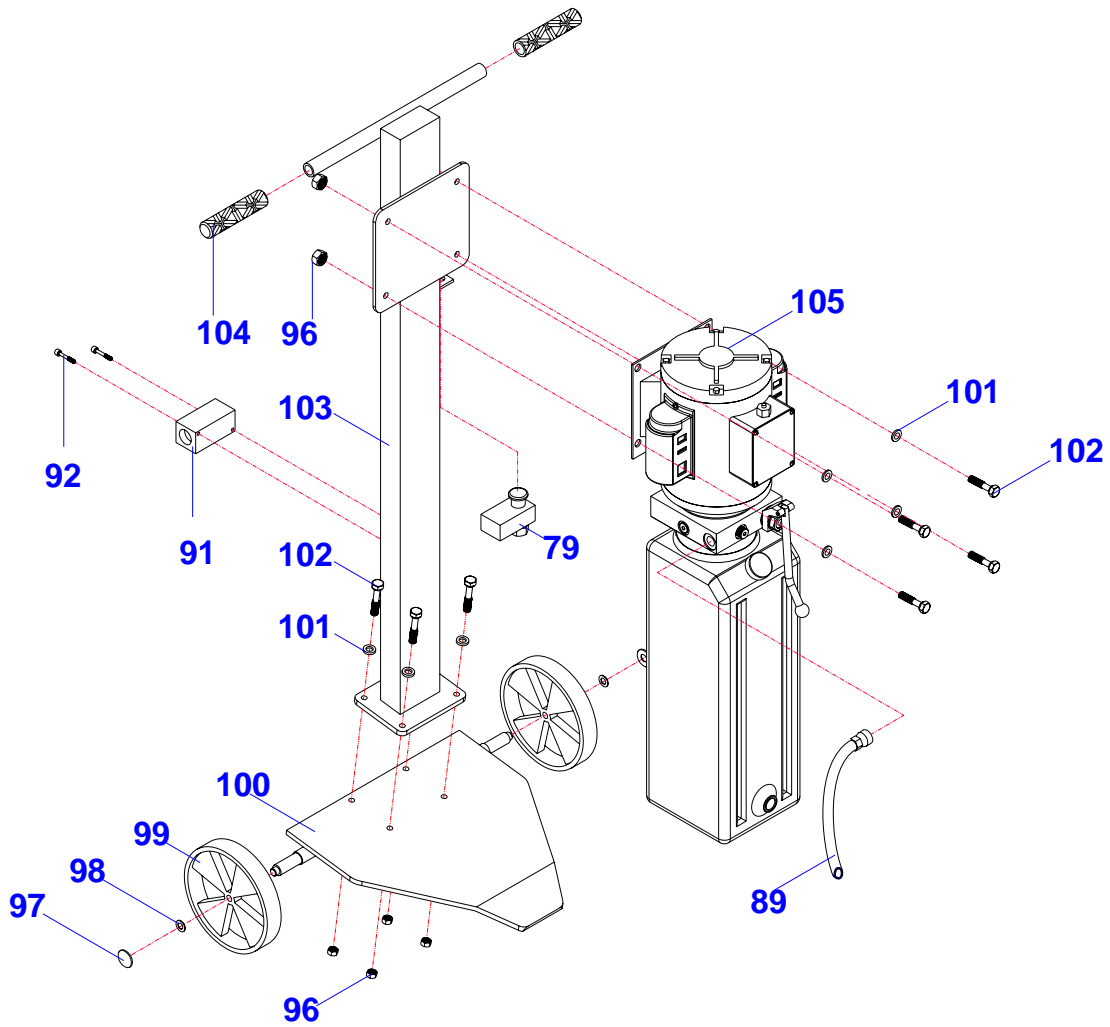

CODE	Part Number	DESCRIPTION	Quantity
79	1611081079	Air valve	1
89	1611081089	Oil hose assy	1
91	1611081091	T union	1
92	1611081092	Hex bolt	2
96	1611081096	Nylon nut	8
97	1611081097	Cover	2
98	1611081098	Flat washer	2
99	1611081099	wheel	2
100	1611081100	Underframe assy	1
101	1611081101	Flat washer	8
102	1611081102	Hex bolt	8
103	1611081103	Column assy	1
104	1611081104	Handle cover	2
105	1611081105	Hydraulic pump assy	1

IMPORTANT

POWER UNIT PRIMING PROCEDURE

THE PROBLEM: Power unit runs fine but will not pump any fluid.

Step 1 – Locate the check valve, the flush plug to the left of the lowering valve.
(See drawing below.)

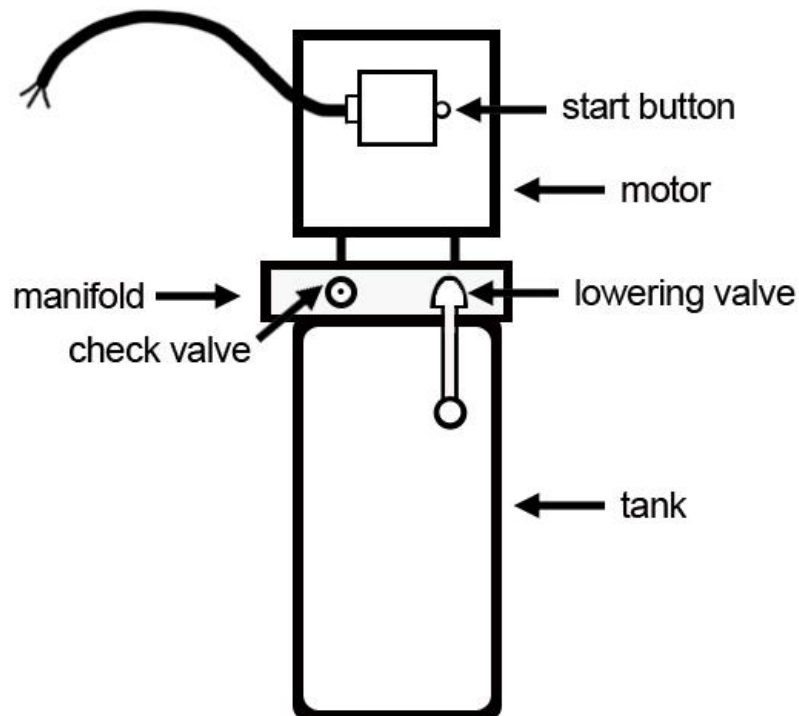

Step 2 – Using an Allen wrench and shop towel – with shop towel in place to catch fluid – loosen the check valve plug 2 ½ turns to allow it to leak.

Step 3 – Push the START button for one second, then release for three seconds.
Repeat these steps until unit starts pumping fluid.

Step 4 – Tighten the check valve plug.

YOUR POWER UNIT SHOULD BE PRIMED