

The Only Space-Saving, Two-Post Lift Designed for Narrow Bays and Low Ceilings

The **GrandPrix™** is a **7,000-lb. capacity two-post car lift** unlike any other. Boasting narrow profile columns that don't consume valuable floor space, as well as a single hydraulic cylinder that offers an incredible 2:1 lift, the GrandPrix provides more power and speed than any ALI-Certified two-post lift in its class. Remarkably, the patent-pending design is the only clear floor two-post lift available that fits in compact garages with ceilings as low as nine feet. The Grand Prix's space-saving design means you don't need to renovate your garage to make room. It's a clear floor two-post lift that's ready-made to fit in virtually any garage. Choose from three models to best suit your needs:

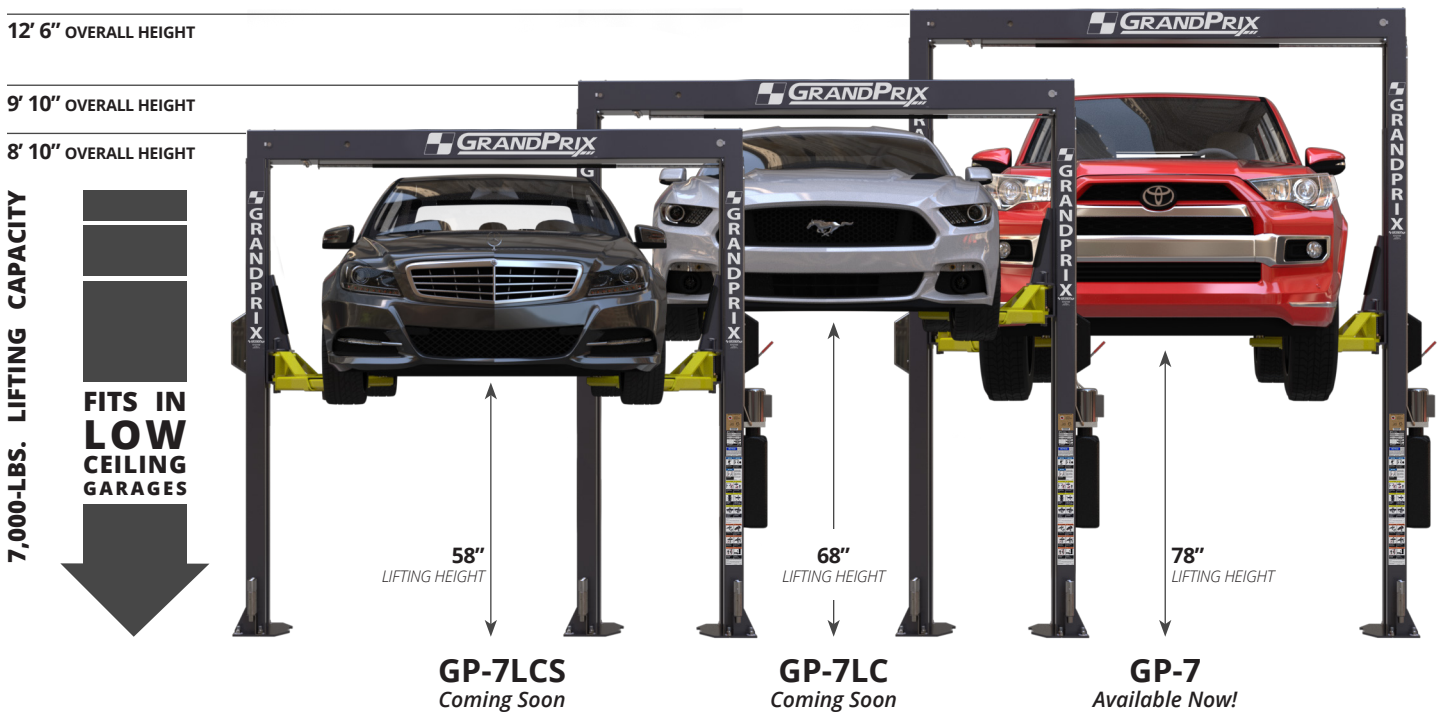

The GrandPrix redefines possibility from a two-post lift design—without breaking the bank. Specifically engineered with the home user and space-constrained shop mechanic in mind, the GrandPrix is equipped with Bi-metric™ arms suited for both symmetric and asymmetric handling of vehicles. That means if you want more door-opening clearance with cars positioned farther to the rear, the Bi-metric arms can accommodate your needs. Or, if you're more of a "center-is-better" type, the purposefully designed dual-positioning arm configuration can handle that too.

Specifically equipped with telescoping low-profile arms, all three GrandPrix models are ready to tackle low ground-clearance vehicles such as race cars and modified imports. Of course, with a robust 7,000-lb. lifting capacity, light-duty trucks and SUVs are no problem at all.

Unfortunately, the car lift world is full of cheap, knock-off lifts with little or no engineering documentation to back up the many vague safety claims that are out there. That's why the Grand Prix offers full ALI Certification: so you get total peace of mind. In addition to being safer than other lifts, the GP-7 series is in a class of its own. Also unlike the others, we actually have complete documentation to back up our claims.

The logo for GrandPrix, featuring a stylized checkered flag icon to the left of the word "GrandPrix" in a bold, italicized sans-serif font.

[See GrandPrix in action!](#)

The patent-pending GrandPrix is the first and only car lift of its kind. The “secret” is really no secret at all: an overhead single cylinder combined with four redundant aircraft cables gives the truly exclusive GP-7 series lifts the advantage over all others. “Regular” two-post designs that feature columns wide enough to contain hydraulic cylinders are much larger, meaning more of your valuable floor space is consumed. We simply removed the cylinders from the columns and positioned the hydraulic muscle overhead. Not only is this ingenious design considerably space-saving, the single overhead cylinder eliminates problematic synchronization issues that are known to plague multi-cylinder two-post lift designs. As they say, the simpler the better.

The massive single hydraulic cylinder combines with oversized dual-hub cable sheaves to raise cars and light trucks fast—incredibly fast—all the while maintaining rugged support. That’s because one inch of cylinder stroke ascends the lift two inches, meaning less hydraulic cylinder wear and reduced runtimes for the motor and hydraulic system. Think of the GP-7 series as a time-saving (both up and down), power saving, wear-and-tear saving, and of course space-saving showpiece that is ready to tackle almost anything that rolls into your shop. Imagine gazing into a shop void of gargantuan columns... and consider how well you’ll appreciate our sleek, modern and entirely impressive design.

If you’ve been hoping and praying for a commercial-grade two-post car lift that’s tailored for typical non-commercial spaces like home garages or narrow bays, then look no further. The GrandPrix never sacrifices strength or cramps your style. With the cost of residential and commercial garage space skyrocketing, elbow room is diminishing, making the need for more compact designs greater than ever. Installing a car lift that has the unique secondary benefit of providing increased and uncluttered floor space in the surrounding area helps create a more ergonomic and comfortable work environment.

When it comes to saving space, innovation is key. You’re going to love the way the GrandPrix transforms your garage, and perhaps even more importantly, you’ll feel that your vision for the perfect car lift has finally become reality..



GrandPrix Specifications

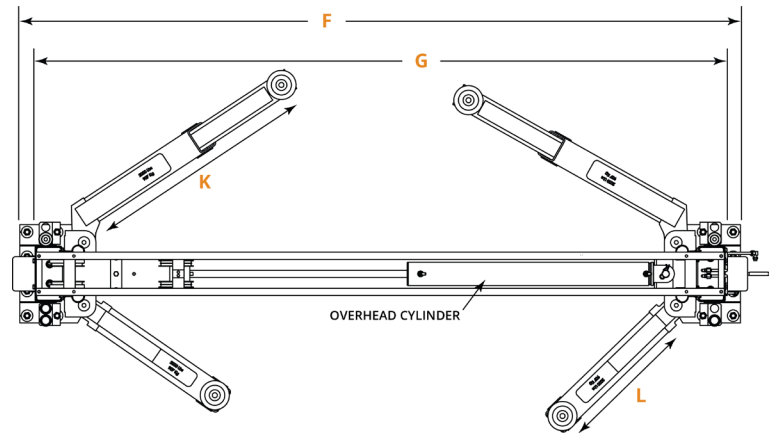
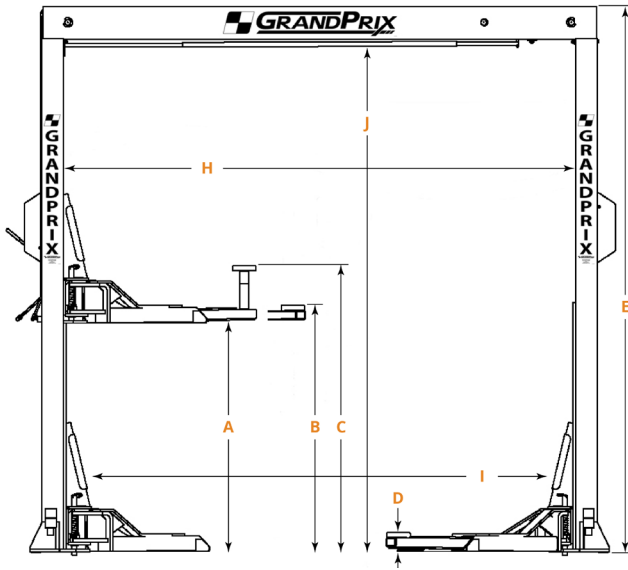

Model:	GP-7LCS	GP-7LC	GP-7
CAPACITY			
Lifting Capacity: (*)		7,000 lbs. / 3,175 kg	
*Max Capacity / Front Axle:		3,500 lbs. / 1,588 kg	
*Max Capacity / Rear Axle:		3,500 lbs. / 1,588 kg	
RISE			
A - Rise:	54" / 1,372 mm	64" / 1,626 mm	74.5" / 1,892 mm
B - Rise + Pad Only:	58" / 1,473 mm	68" / 1,727 mm	78" / 1,981 mm
C - Rise + Pad + Adapter:	66" / 1,676 mm	76" / 1,930 mm	86.5" / 2,197 mm
D - Min. Height + Pad:	4.5" / 114 mm	4.5" / 114 mm	4.5" / 114 mm
Time to Full Rise:	45 seconds	50 seconds	55 seconds
OUTSIDE DIMENSIONS			
E - Height Overall:	106.5" / 2,705 mm	118.5" / 3,010 mm	150" / 3,810 mm
F - Width Overall:		125" / 3,175 mm	
G - Outside Columns:		119.5" / 3,035 mm	
INSIDE DIMENSIONS			
H - Inside Columns:		110" / 2,794 mm	
I - Drive-Thru Clearance:		89.5" / 2,273 mm	
J - Floor To Overhead Switch:	96" / 2,438 mm	108" / 2,743 mm	140" / 3,556 mm
ARMS & PADS			
K - Front Arm Reach: (MIN)	26" / 660 mm	26" / 660 mm	26" / 660 mm
K - Front Arm Reach: (MAX)	42" / 1,067 mm	42" / 1,067 mm	42" / 1,067 mm
L - Rear Arm Reach: (MIN)	28" / 711 mm	28" / 711 mm	28" / 711 mm
L - Rear Arm Reach: (MAX)	47.5" / 1,207 mm	47.5" / 1,207 mm	47.5" / 1,207 mm
Max Load Per Arm:		1,750 lbs. / 794 kg	
ELECTRICAL			
Motor:		220 VAC / 60 Hz. 1Ph.	
Noise:		45 dB	

Telescoping Low-Pro™ arms for sports cars

If you work with low ground-clearance vehicles, such as race cars, sports cars and modifieds, you'll appreciate the ground-hugging profile our Low-Pro arms have to offer. These telescoping arms rest lower to the ground, making it possible to service low-stance vehicles.

Asymmetric & symmetric arm configuration

The GrandPrix is equipped with Bi-metric™ arms suited for both symmetric and asymmetric handling of vehicles. Variable arm positioning for either symmetrical or asymmetrical configuration offers greater versatility for increased service capabilities. It's like having 2 car lifts in 1.

Lowered arm tube supports

Unobstructed door-opening clearance and door damage prevention are essential aspects in every two-post design. Mitigating risk of door dents and dings starts out by eliminating the risk entirely. That's why our arm tube supports are lowered and gradually tapered, providing unhindered range of motion when opening vehicle doors.

Automatic arm restraints

The telescoping arms of the GrandPrix series feature arm restraints that interlock automatically when the lift rises off the ground, adding an added measure of safety and assurance that the arms will be held strongly in place during use. When the lift is lowered to the ground, the restraints disengage. This enables free movement of the arms, so they can be moved out of the way for easy vehicle exit.

Simple operation

Our standard electric-hydraulic power unit is built with precision components that assure trouble-free operation and maximum durability. Ergonomic controls combine with automatic safety locks to permit simple and safe operation.

Taller lift carriages

Lift carriages are the lifting assemblies that the car lift arms attach to. At a lofty 53" in height, our GP-7 two-post lift carriage is substantially taller than most other two-post designs, which enables us to reduce column, carriage and load bearing stresses.



Automatic safety locks

Rugged load-holding safety lock devices automatically engage and lock the lift structure as the car lift rises, preventing sudden free-fall in the unlikely event of suspension component failure. A convenient single-point safety lock handle releases both column locks simultaneously. For added safety, a secondary lock system acts as an automatic slack-cable device, automatically engaging in the event of an unexpected cable failure.

Single hidden hydraulic cylinder

A single overhead cylinder means no more problematic synchronization issues that are known to plague multi-cylinder two-post lift designs. Our proprietary hydraulic power system is teamed with oversized dual-hub cable sheaves that together deliver a 2:1 lifting ratio, raising cars and light trucks incredibly fast. The micro-smooth chrome piston rod is machined from high-yield C-1045/50 micro-alloy steel and is paired with an industrial single-piece, pilot-fitted, machined steel piston. High durometer, mechanically-loaded rod seals make leakage a thing of the past, while specially formulated abrasion-resistant urethane rod wipers provide extrusion protection. This combination of superb base materials and superior processing ensures optimum efficiency and longevity. An integrated flow restrictor provides a controlled descent in the case of an unexpected hose rupture.

Redundant redundancy

Each GrandPrix lift is supplied with four high-strength galvanized steel lifting cables, each with a tensile strength of over 15,000 pounds. That's 60,000 pounds of brawny steel cable to safely support up to 7,000 pounds. Even though only two cables are actually necessary for a GrandPrix lift to operate, we purposely added two additional independent and totally separate cables to ride along as added security in the rare case of a cable failure. That means that if any one of the primary 15,000-pound cables fails, there is a backup cable on-guard, a load sentry that will quickly spring into action.

Now comes the fun part. Let's say that for whatever reason, a primary cable fails (highly unlikely). The backup cable will instantly take over the heavy lifting role. Now, imagine that for some apocalyptic reason, one of the secondary backup cables fails as well—what then? This is what our engineers are most proud of. Integrated into the design as a kind-of behind the scenes, all-inclusive safety net is an ingenious little device our engineers cleverly called out as "GP-7 CABLE BREAK SAFETY, PART NUMBER 5600694".

Below identifies the redundancy built into every GrandPrix lift. (As if a safety factor on the lifting cables exceeding 800% is not respectable enough).

1. Every GrandPrix lift is equipped with rugged load-holding safety lock devices that prevent sudden free fall in the unlikely event of a suspension component failure.
2. By nature, wire rope is a redundant system in itself—a redundant structure made from a number of parallel load-bearing elements that are twisted together to allow the assembly to operate as a cohesive whole.
3. When it comes to built-in safety factors, we've got gobs of them. From the overstated cables to the entire lift structure—and that's when loaded to max capacity. Lift less than 7,000 lbs. and the abundant safety factors start stacking up even more, adding a whole new level of assurance.
4. We include secondary backup cables.
5. We feature spring-loaded cable break safeties that act as slack-cable locks in case of backup cable failure.

The gold label of safety*

There's only one nationally recognized safety standard for vehicle lifts: ANSI/ALI ALCTV (current edition) "Safety Requirements for the Construction, Testing and Validation of Automotive Lifts", administered by the Automotive Lift Institute. ALI certification is a buyer's-only guarantee that the lift meets industry safety and performance standards.

*Only the GP-7 model is currently certified. ALI certification is currently pending on GP-7LCS and GP-7LC models.



 **GRANDPRIX**

GRANDPRIX

GRANDPRIX



 **GRANDPRIX**