

XPR-9S

Two-Post Lifts

SKU# 5175390

9,000-lb. Capacity, Floorplate, Chain-Over, Adjustable Width, Screw Pads, SHORTY

Questions? Contact BendPak's Sales Team

sales@bendpak.com | 1-800-253-2363

Monday - Friday, 6AM to 4:30PM PST

XPR-9S Two-Post Lift is Perfect for Cars, Trucks and SUVs

Our newest line of XPR-Series [2-Post Car Lifts](#) is designed to provide pros and hobbyists alike with a wide selection of durable, safe and reliable systems for virtually every lifting application. Powerful and secure, BendPak's XPR-9S is CE approved, certified and meets or exceeds the standards prescribed by European Standard EN 1493. The XPR-9S in particular has an incredibly rapid lifting speed and a robust menu of features to increase efficiency and productivity, but with fewer serviceable parts and reduced necessary maintenance. The results are lower operating expenses and higher productivity. If you're looking to do more in less time than ever before, you'll find that the short-style XPR-9S automobile lift is the perfect addition to your shop.



Options

SKU#	Model	Description
5175391	XPR-9S-LP	Low-Profile Arms

Features

- 9,000-lb lifting capacity
- CE Approved and Certified. Meets or exceeds the standards prescribed by European Standard EN 1493
- Shorter column for low-ceiling installations
- Adjustable wide or narrow drive-thru configurations
- Extended rise gives you over 6 feet of under clearance
- Single-piece columns
- Single-point safety release
- Drop-end arms provide a lower pad height
- Chain-lifting system combined with dual hydraulic cylinders
- Electric / hydraulic power system
- Large 20" x 19" steel base plates
- Self-lubricating dura-glide polyethylene bearing system
- Safety locks in each column spaced every 3-inches
- Automatic arm restraints
- Dual 3/8" equalizer cables with oversized cable sheaves
- 4-piece 63 mm stackable adapter set comes standard

Two-Stage Telescoping Screw Pad Assembly Kit

The XPR-9S two-post lift utilizes our double-telescoping screw pads. These pads are resistant to tearing and gouging. Their thick, rugged construction ensures safe operation when used in your workplace. 63 mm stackable adapters are included as a standard set to accompany each lift, helping reach the lifting points on any vehicle.

Low-profile, dropped-end frame contact pads

From race cars to lowered compact vehicles, this car lift has the versatility to get under your chassis without damaging your vehicle's body or frame.

Triple-telescoping front arms and two-stage rear arms

Multi-stage arms are versatile enough to handle whatever you need lifted. The arm sweep and minimum arm reach on this lift are extended, so the arms can lift vehicles with unibody construction. They precisely touch OEM-recommended lift points, accommodating wide and narrow wheelbases.

Lowered arm tube supports

Our tube arms have been reconfigured to make it easier to open doors when vehicle lift points are engaged by the car lift. This is especially useful if your vehicle has low-hanging doors. We take every measure to prevent damage to your property with our two-post lift design.

Specifications



Model	XPR-9S	XPR-9DS	XPR-12FDL
Style	Chain-Over / Adjustable Width	Direct-Drive / Adjustable Width	Direct-Drive
SKU#	5175390	5175393	5175403
Lifting Capacity	9,000 lbs. (4,082 kg)	9,000 lbs. (4,082 kg)	12,000 lbs. (5,443 kg)
A - Rise	72" (1,829 mm)	69" (1,753 mm)	69" (1,753 mm)
B - Rise + Pad Only	78" (1,981 mm)	75" (1,905 mm)	74" (1,880 mm)
C - Max. Lifting Height	80.5" (2,044 mm)	77.5" (1,968 mm)	79" (2,007 mm)
D - Min. Height + Pad	4.25" (108 mm)	4.25" (108 mm)	5" (127 mm)
E - Height Overall	113" (2,870 mm)	145" (3,683 mm)	144" (3,403 mm)
F - Width Overall	132" (3,353 mm) - 145" (3,683 mm)	132" (3,353 mm) - 145" (3,683 mm)	155" (3,937 mm)
G - Outside Columns	126.75" (3,225 mm) - 139.75" (3,555 mm)	126.75" (3,225 mm) - 139.75" (3,555 mm)	146" (3,708 mm)
H - Inside Columns	105" (2,667 mm) - 118" (2,997 mm)	105" (2,667 mm) - 118" (2,997 mm)	118" (2,997 mm)
I - Drive-Thru Clearance	93" (2,362 mm) - 106" (2,692 mm)	93" (2,362 mm) - 106" (2,692 mm)	103" (2,616 mm)
J - Front Arm Reach (MIN)	28.5" (724 mm)	27.5" (698 mm)	39" (991 mm)
J - Front Arm Reach (MAX)	47.5" (1,206 mm)	51.5" (1,308 mm)	59" (1,499 mm)
K - Rear Arm Reach (MIN)	28.5" (24 mm)	34" (863 mm)	39" (991 mm)
K - Rear Arm Reach (MAX)	47.5" (1,206 mm)	54.5" (1,384 mm)	59" (1,499 mm)
Screw Pad Adjustment	1.75" (44.5 mm)	1.75" (44.5 mm)	N/A
Max. Load per Arm	2,250 lbs. (1,021 kg)	2,250 lbs. (1,021 kg)	3,000 lbs. (1,361 kg)
L - Floorplate Height	1.75" (44 mm)	1.75" (44 mm)	2" (51 mm)
M - Floorplate Width	8.5" (216 mm)	8.5" (216 mm)	8.5" (216 mm)
Time to Full Rise	45 seconds	45 seconds	55 seconds
Noise	45 dB	45 dB	45 dB
Motor	220 VAC / 60 Hz / 1 Ph	220 VAC / 60 Hz / 1 Ph	220 VAC / 60 Hz / 1 Ph

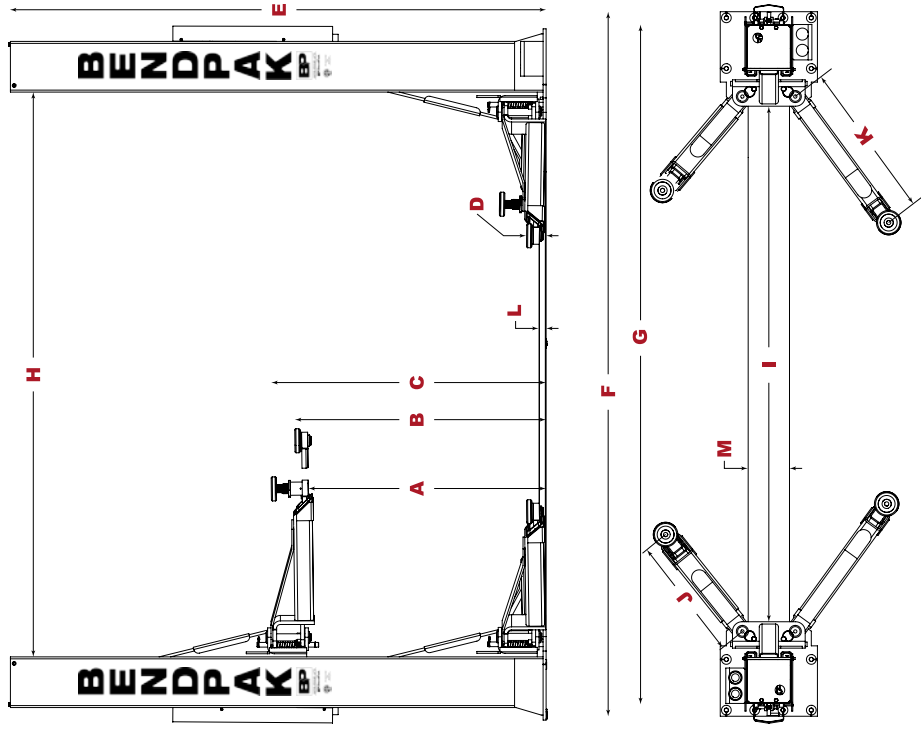

Not all BendPak lift models meet the standards as prescribed by ANSI/ALI ALCTV-2017 or ANSI/JUL 201. Consult www.autolift.org for a complete list or contact BendPak via contact@bendpak.com.